

Orthogonal Frequency Division Multiplexing

Mark Elo, Marketing Director of RF Products, Keithley Instruments

Orthogonal frequency division multiplexing (OFDM) is a form of digital modulation used in a wide array of communications systems. This paper will explain what OFDM is, why it's important, where it's used, and what test instrumentation is required to maintain it.

Perhaps we should first explain what is so special about OFDM. Three things stand out.

OFDM is spectrally efficient, carrying more data per unit of bandwidth than such services as GSM and W-CDMA. *Figure 1* shows a comparison of the spectral efficiency of the leading cellular technologies and how they compare to WLAN and WiMAX. Fourth Generation technology, often referred to as the Long Term Evolution of wireless (LTE) and Ultra Mobile Broadband (UMB) for cellular devices, plans to use OFDM or OFDMA.

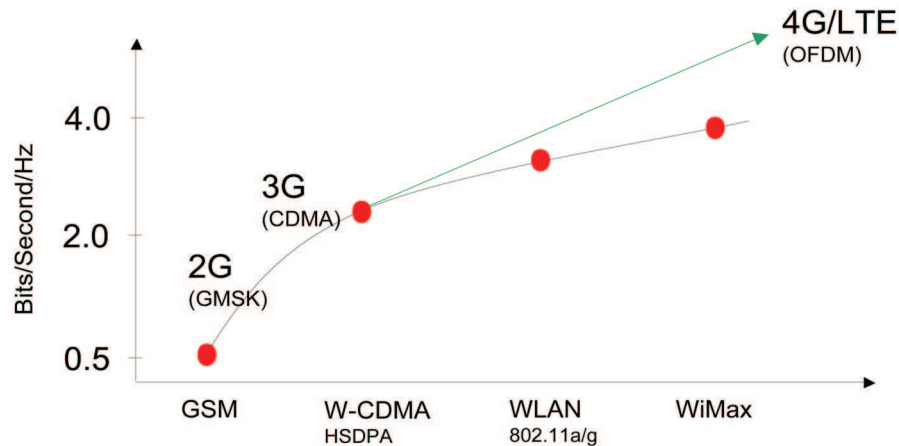

Figure 1. The spectral efficiency of the leading cellular technologies and how they compare to WLAN and WiMAX. Fourth Generation technology, often referred to as LTE, or the Long Term Evolution of wireless for cellular devices, will use OFDM.

OFDM tolerates environments with high RF interference. Some services that use OFDM — such as WLAN — operate in the unregulated ISM (Industrial Scientific Medical) bands, where they must co-exist with many unregulated devices, including analog cordless phones (900MHz), microwave ovens (2.45GHz), Bluetooth devices (2.45GHz), digital cordless phones (2.45GHz or 5.8GHz) and Wireless LAN (2.45GHz or 5.8GHz).

Finally, OFDM works well in harsh multi-path environments, as we shall see.

Digital Modulation Overview

Most forms of digital transmission involve modulating a pair of summed sine waves that differ in phase by 90°. The modulation signal can be represented by the vector sum of the in-phase (I) and quadrature (Q) components, as shown in *Figure 2*.

Digital Modulation Overview

I and Q Components of a Signal

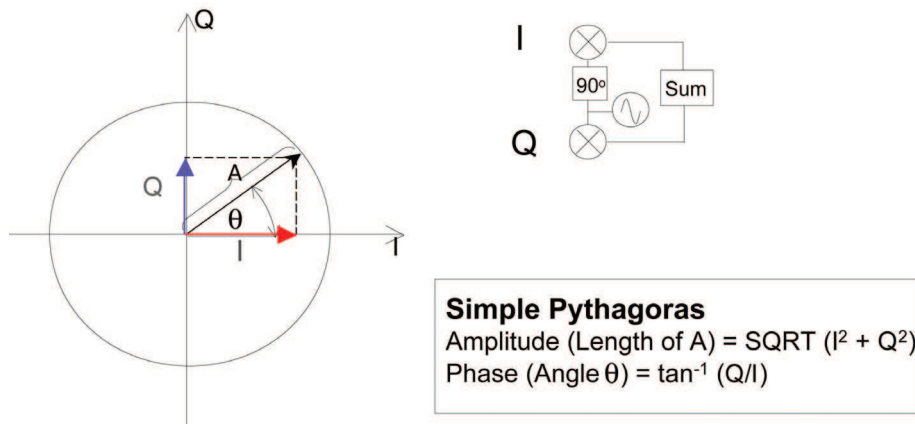

Figure 2. Most forms of digital transmission involve modulating a pair of sine waves that differ in phase by 90°. The modulation signal can be represented by the vector sum of the in-phase (I) and quadrature (Q) components.

There are many ways to encode digital information in this way. If you change the phase relationships between the two sine waves, the result is called phase shift keying (PSK). A common type of PSK is quadrature phase shift keying (QPSK), which uses four phases; if eight phases are used, the result is 8PSK.

If you vary both the amplitude and phase of the two sine waves, the result is quadrature amplitude modulation (QAM).

The best way to analyze the resulting signals is with a vector signal analyzer (VSA), such as the Model 2820, that processes all its data as quadrature pairs in a constellation diagram; **Figure 3** shows constellation diagrams for several types of modulations: QPSK, 8PSK, and 16QAM.

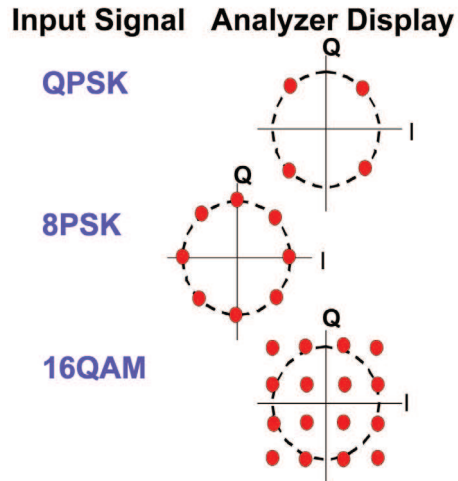

Figure 3. Constellation diagrams for several types of modulation.

Modulation Quality Analysis

A good measurement of the quality of a received digital signal is Error Vector Magnitude, or EVM (*Figure 4*). This is the ratio of the received signal's amplitude and phase compared to its ideal amplitude and phase. Mathematically, EVM is given by

$$EVM = \sqrt{\frac{P_{error}}{P_{reference}}} \cdot 100\%$$

or

$$EVM (dB) = 10 \log_{10} \left(\frac{P_{error}}{P_{reference}} \right)$$

Cellular technology specifications are usually stated in percent, while the Wireless LAN community tends to specify EVM using decibels.

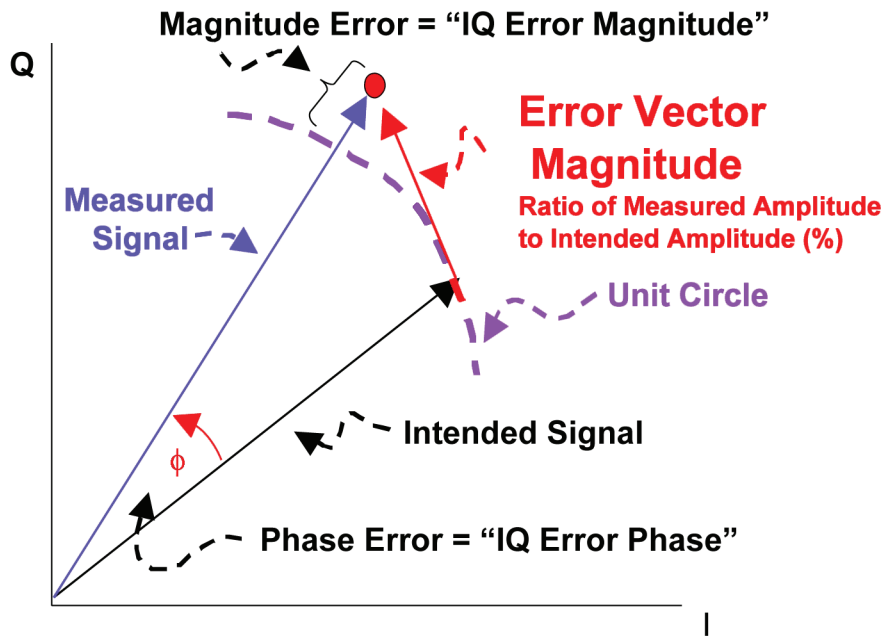

Figure 4. The main measurement for the quality of a received digital signal is Error Vector Magnitude, or EVM. This is the ratio of the received signal's amplitude and phase compared to its ideal amplitude and phase.

The Multi-Path Problem

Multi-path adds another layer of complexity to our EVM measurement. *Figure 5* shows a Bluetooth signal with a symbol rate of 1M symbols per second. That means that the receiver will expect a specific symbol within a window of one microsecond. If multi-path delays the signal by more than one microsecond, the receiver will receive the symbol in the next symbol period, causing a significant symbol error.

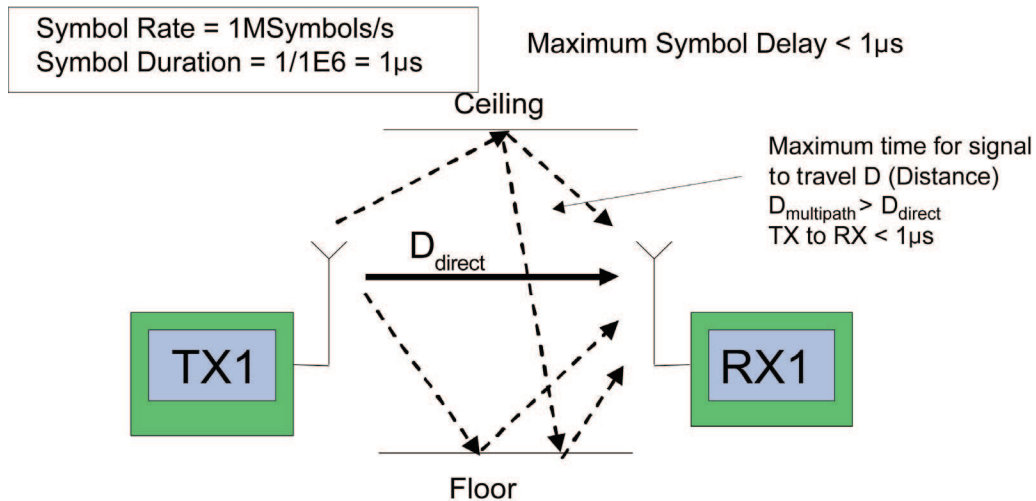

Figure 5. If the difference in path length between direct and reflected paths exceeds 1 microsecond, the receiver will receive the symbol in the next symbol period.

The faster the data rate, the higher the chance that multi-path will cause Inter Symbol Interference (ISI). An obvious way to reduce the error rate would be to slow down the symbol rate; each symbol would last longer and be more resistant to multipath. Unfortunately, this reduces the data rate. What's needed is a way to slow down the symbol rate without slowing the data rate — a seemingly impossible task. The answer to the puzzle is OFDM.

OFDM transmits a large number of closely-spaced carrier waves, each modulated with a different signal. *Figure 6* shows that the individual I and Q input signals are translated into separate carriers. The symbol rate for each carrier is low, making it resistant to multipath, but because there are so many carriers the overall data rate is high. Adjacent carriers are in phase quadrature with each other, which keeps crosstalk between them to a minimum without requiring a bank of narrow-band filters.

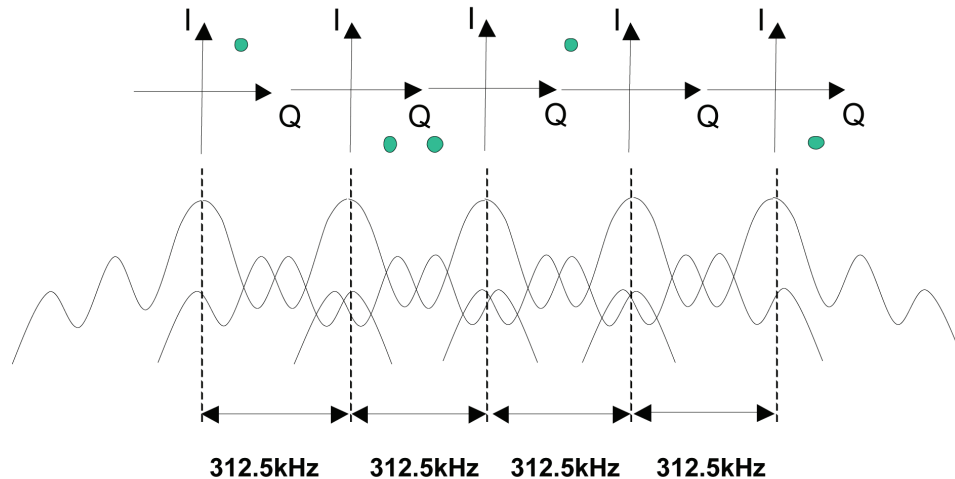

Figure 6. Instead of transmitting a single symbol at a time, OFDM transmits multiple symbols simultaneously on a number of carriers. This is the Frequency Division Multiplex component. The sub-carriers are distributed in carefully chosen multiples of frequency so that they are "orthogonal" and the closely adjacent sub-carriers don't interfere with each other.

The OFDM Radio

As you can see, a lot of complex math is involved in this. Many conventional instruments lack the signal processing capability to perform these measurements quickly. As shown in Figure 7, Keithley's DSP enhanced architecture makes it possible to perform the analysis very quickly.

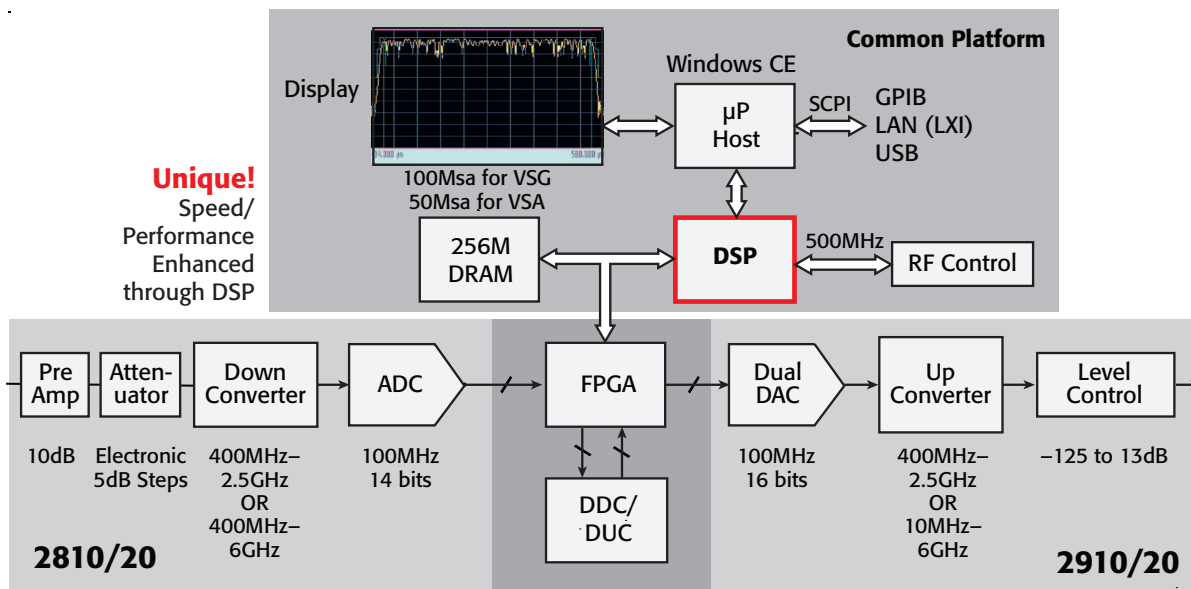

Figure 7. This block diagram shows the digital circuit in the Model 2810 Vector Signal Analyzer and the Model 2910 Vector Signal Generator.

OFDM is simple in concept, even though its implementation is complex. Mathematically, it can be implemented by using an Inverse Fast Fourier Transform (IFFT) in the transmitter and conversely an FFT in the receiver. *Figure 8* shows the parallel symbols being converted to the two modulated sine waves in the output. It's as if the IFFT acts as a specialized multiplexer.

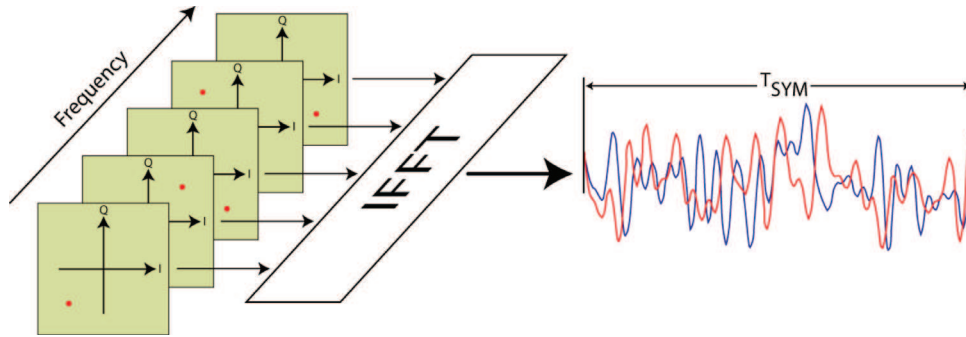

Figure 8. OFDM can be implemented by using an Inverse Fast Fourier Transform (IFFT) in the transmitter and conversely an FFT in the receiver. In the transmitter, the IFFT converts the parallel input signals into the two modulated sine waves in the output. It's as if the IFFT acts as a specialized multiplexer.

In order to keep things synchronized, an OFDM signal includes several sub-carriers (*Figure 9*) designated as pilot carriers that are used as reference for phase and amplitude for synchronizing the receiver as it demodulates the data in the other sub-carriers.

- **Used as reference for phase and amplitude to demodulate the data in the other sub-carriers.**

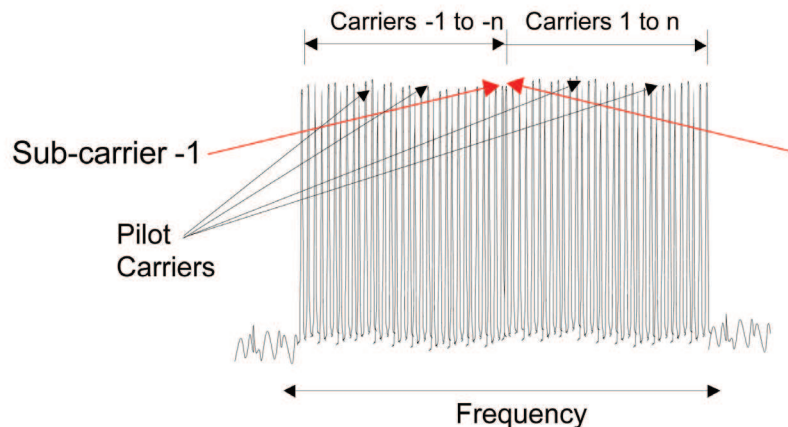
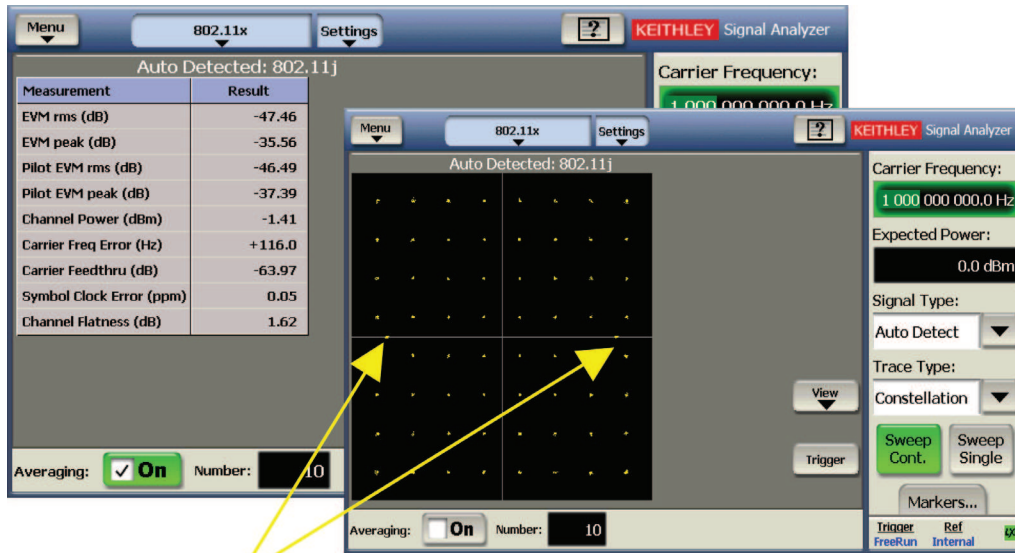

Figure 9. An OFDM signal includes several sub-carriers designated as pilot carriers that are used as reference for phase and amplitude for synchronizing the receiver as it demodulates the data in the other sub-carriers.

Key Measurements: Constellation and EVM

Figure 10 shows the constellation of a WLAN signal conforming to the 802.11j standard. Note that even though the signal has been transmitted using many carriers, it is still essentially a QAM signal. There are also two extra symbols, representing the information modulated on the pilot carriers.



Pilot Symbols

Figure 10. The constellation diagram of a WLAN signal conforming to the 802.11j standard. Note that even though the signal has been transmitted using many carriers, it is still essentially a QAM signal. There are also two extra symbols, representing the information modulated on the pilot carriers.

OFDM is very pervasive, as shown in Table 1.

Table 1: Communication services using OFDM

Wireless	Wireline
IEEE 802.11a, g, n (WiFi) Wireless LANs	ADSL and VDSL broadband access via POTS copper wiring
IEEE 802.15.3a Ultra Wideband (UWB) Wireless PAN	MoCA (Multi-media over Coax Alliance) home networking
IEEE 802.16d, e (WiMAX), WiBro, and HiperMAN Wireless MANs	PLC (Power Line Communication)
IEEE 802.20 Mobile Broadband Wireless Access (MBWA)	
DVB (Digital Video Broadcast) terrestrial TV systems: DVB-T, DVB-H, T-DMB, and ISDB-T	
DAB (Digital Audio Broadcast) systems: EUREKA 147, Digital Radio Mondiale, HD Radio, T-DMB, and ISDB-TSB	
Flash-OFDM cellular systems	
3GPP UMTS & 3GPP@ LTE (Long-Term Evolution) and 4G	

WLAN

WLAN is defined by the IEEE 802.11 standard, of which there are several variations, a through g, as shown in *Table 2*. Within a 16.25MHz bandwidth are 52 carriers (*Figure 11*), numbered -26 to $+26$, spaced 312.5kHz apart. Carriers 7 and 21 (-21 , -7 , $+7$ and $+21$) are the pilots. The packet structure is Preamble – Header – Data Block, and the sub-carrier modulation types are BPSK, QPSK, 16-QAM, or 64-QAM.

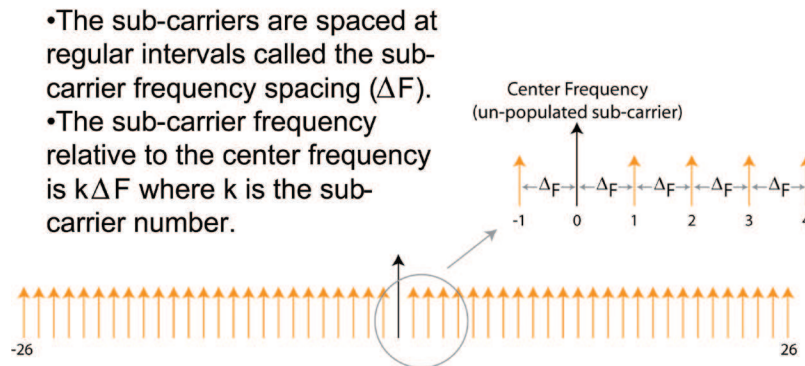

Figure 11. Each carrier within the modulation scheme is referred to as a sub-carrier. The sub-carriers are spaced at regular intervals called the sub-carrier frequency spacing (ΔF). The sub-carrier frequency relative to the center frequency is $k\Delta F$ where k is the sub-carrier number.

Table 2: WLAN Summary

802.11	Means
a	54Mbps OFDM, 5.9GHz Band, 20MHz channels
b	11Mbps CCK, 2.4GHz (Legacy, not OFDM)
g	What you can easily buy now – same as a, but at 2.4GHz
j	Japanese version of g that uses half the sample rate
n	<ul style="list-style-type: none"> • Not a finished standard yet • Like g, but up to 600 Mbps • OFDM • MIMO • 20 and 40MHz channels

The original WLAN standard is 802.11b, which is not based on OFDM. a and g are the same: a works in the 5GHz ISM band and g works in the 2.4GHz ISM band. j is a slower symbol rate version of g for the Japanese market, and n is based on MIMO technology, which is covered in another white paper.

Several organizations are involved with WLAN: WiFi is an industry consortium that defines a required subset of 802.11 to ensure better operation between different vendors' equipment, while EWC is an industry consortium that took the unfinished n standard, agreed upon a version, and is attempting to field solutions prior to 802.11N ratification.

Test Equipment Requirements for WLAN

Test equipment for WLAN must have a frequency range up to about 6GHz and be able to modulate or demodulate OFDM signals with a bandwidth of up to 16.25MHz for all types apart from 802.11n, which has a maximum bandwidth of 40MHz.

So far we've looked at OFDM. In OFDM all the carriers are used to facilitate a single link. OFDMA (Orthogonal Frequency Division Multiple Access) assigns different groups of sub-carriers to different users in a similar fashion as in CDMA. OFDMA's best-known use is in WiMAX.

WiMAX

WiMAX, or the Worldwide Interoperability for Microwave Access, is very similar in concept to 802.11, but the demands of multiple simultaneous users make the implementation much more complex.

There are two major variations of WiMAX: fixed and mobile. The mobile version, 802.16e-2005 (often called 802.16e), facilitates the link between mobile devices. It uses SOFDMA (Scalable OFDM Multiple Access), which interoperates with OFDMA but requires new equipment. 802.16e also adds MIMO (Multiple-Input Multiple-Output), which is the subject of another white paper.

The fixed version of WiMAX, 802.16-2004 (often called 802.16d), uses OFDMA and operates from 2–11GHz (no regulatory approval above 5.9GHz); it delivers a practical data rate of 10Mbps over 2km.

The differences are summarized in *Table 3*.

Table 3: Fixed and mobile WiMAX

802.16	Means
	Fielded system for fixed-point access (to the home or office)
802.16-2004 (aka 802.16d)	OFDMA (OFDM multiple access) 2–11GHz (no regulatory approval above 5.9GHz) Practical rate: 10Mbps over 2km
802.16e-2005	The current version of the standard, upgraded to include mobile wireless SOFDMA (Scalable OFDM Multiple Access) SOFDMA interoperates with OFDMA, but requires new equipment Adds MIMO

Fixed WiMAX is similar in some respects to WLAN, i.e., it has an OFDM physical layer. Mobile WiMAX is based on an OFDMA physical layer. It uses both frequency division multiplex and time division multiplex. Groups of sub-carriers (*Figure 12*) represent individual data streams. Each group of sub-carriers also has a frame structure.

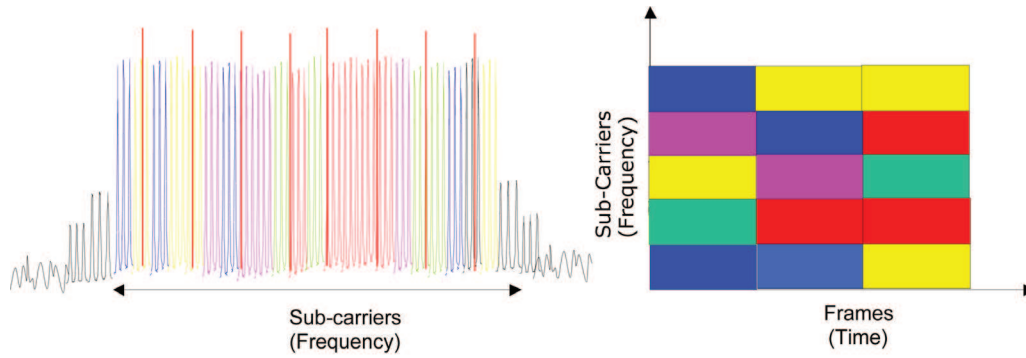

Figure 12. Mobile WiMAX uses both frequency division multiplex and time division multiplex. Groups of sub-carriers represent individual data streams. Each group of sub-carriers also has a frame structure.

Time division characteristics are shown in Figure 13. The frame structure equates to a packet. There is a timing gap between the uplink and downlink called the transition gap.

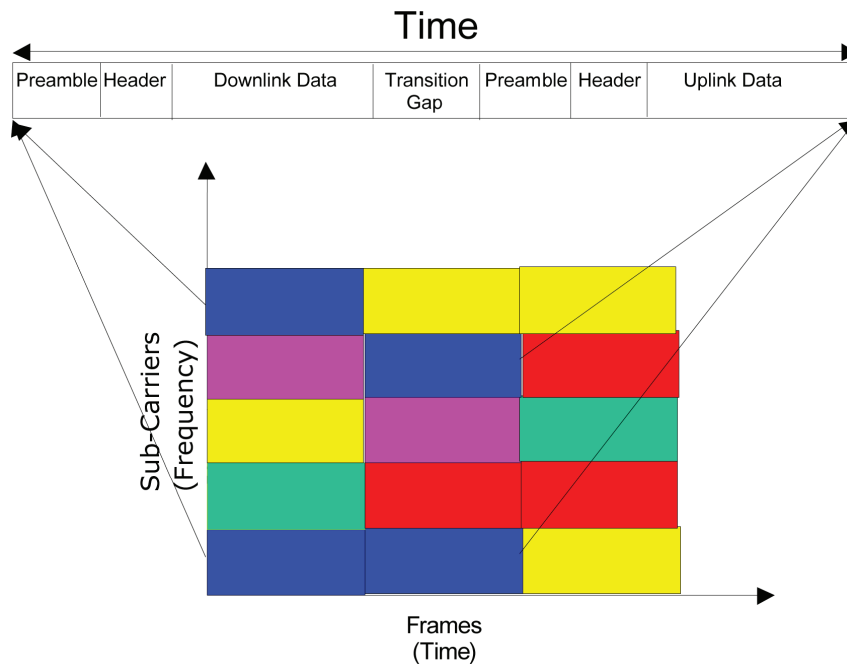

Figure 13. Time division characteristics are shown in Figure 13. The frame structure equates to a packet. There is a timing gap between the uplink and downlink called the transition gap.

Mobile WiMAX is a dynamic system. The amount of data transferred is a function of the modulation type and symbol rate on each set of sub-carriers. If the link quality is good, a high throughput modulation type such as QAM is used, and most of the bandwidth is consumed,

thus limiting the number of users on the system. As the user moves further away from the base station, the signal quality decreases, and with it the ability to maintain a high throughput. A lower throughput modulation scheme such as QPSK would then be employed. This, of course, does not require a large group of sub-carriers, so the system can support more users.

Figure 14 shows two WiMAX measurements that the Keithley Model 2820 can perform. We can see a packet structure containing downlink and uplink data, DL and UL, each separated by a transition gap. The UL contains more data and would use a complex modulation format such as QAM. This is what we have chosen to demodulate, although we could also demodulate the DL portion, which is QPSK. We can even demodulate both and display a hybrid of the two modulation types in the constellation.

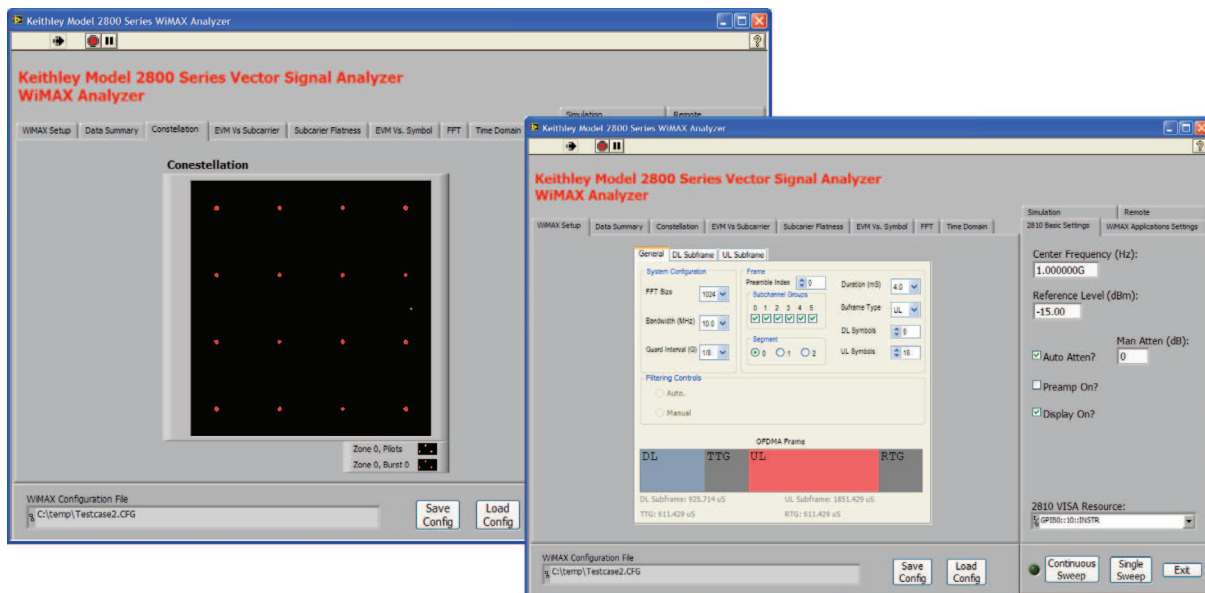

Figure 14. In this WiMAX measurement, we see a packet structure containing downlink and uplink data, DL and UL, each separated by a transition gap. The UL contains more data and would use a complex modulation format such as QAM. This is what we have chosen to demodulate, although we could also demodulate the DL portion, which is QPSK. We can even demodulate both and display a hybrid of the two modulation types in the constellation.

Conclusions

In terms of speed versus mobility, the WLAN and WiMAX standards provide a marked increase in data speed over traditional cellular based communications technology.

The future of wireless and of fourth generation cellular systems, such as LTE or UWB, will be based on a combination of OFDM types of modulation and MIMO radio configurations (*Figure 15*). When choosing test equipment for testing today's radio standards,

it's important to consider the evolution of wireless technology and to ensure that your purchases are forward compatible.

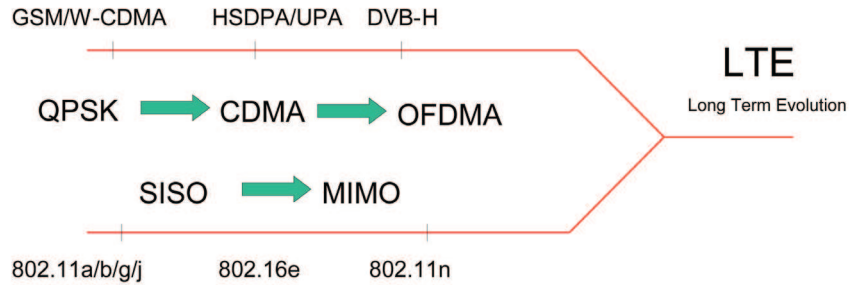
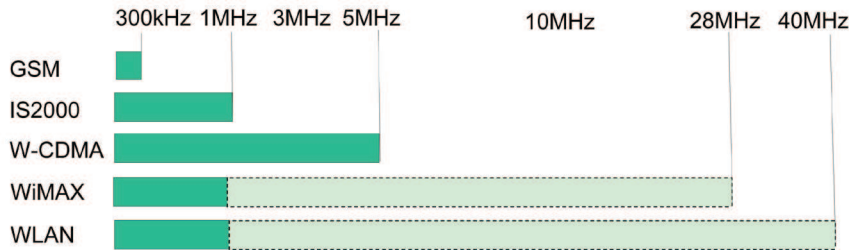

Figure 15. The long term evolution (LTE) of wireless and of fourth generation cellular systems will be based on a combination of OFDM types of modulation and MIMO radio configurations. When choosing test equipment for testing today's radio standards, it's important to consider the evolution of wireless technology and to ensure that your purchases are forward compatible.

One key consideration for instrumentation is bandwidth; WiMAX and WLAN have bandwidths that can exceed 25MHz. As shown in **Figure 16**, the Keithley range of wireless equipment has 40MHz of bandwidth as standard, creating a new price performance point in the market place.



Keithley instruments have 40MHz BW as standard.

Figure 16. One key consideration for instrumentation is bandwidth; WiMAX and WLAN have bandwidths that can exceed 25MHz. The Keithley analyzers have 40MHz of bandwidth as standard, while the generators have arbitrary waveforms available with 20, 40 and 80MHz bandwidth, creating a new price performance point in the market place.